

HITACHI
Inspire the Next

CP-X265

The Hitachi CP-X265 is a 2500 ANSI Lumen desktop video and data projector, perfect for high end business or education use. The CP-X265 includes networking features for control through the internet, as well as a host of security and video enhancement features - all at an affordable price.

- 2500 ANSI Lumens with Optical Zoom
- Network Capable for controlling & monitoring, WEB Control, E-shot and scheduling function
- Full Connectivity
- Quick Start and Instant Off
- Auto Vertical Keystone
- Input Source Naming
- My Button
- Resolution Preset
- Whiteboard Mode and Blackboard Mode
- Anti Theft Features:
 - Pin-lock
 - My Screen Lock
 - Transition Detector



- **2500 ANSI Lumens** with optical zoom.
- **Full Connectivity** - 2 x RGB in and RGB monitor out with audio in/out and versatile video connections.



- **Quick Start and Instant Off** - These features are ideal for quick presentations. The image will appear in just 3 seconds after power on and the unit can be instantly powered off after a presentation.
- **Auto Vertical Keystone** - Just press the button for a perfect screen setting.
- **Input Source Naming** - The name of any input can be changed to one of your own choosing for easier use.



- **My Button** - There are 2 user programmable buttons on the remote control that may be set with any command. The user can set up these buttons from a simple, easy to understand menu.
- **'Resolution Preset'** ensures special resolutions, such as WXGA will be recognised and resized and placed in the optimum position. Custom modes can also be stored to remember user's own resolutions.

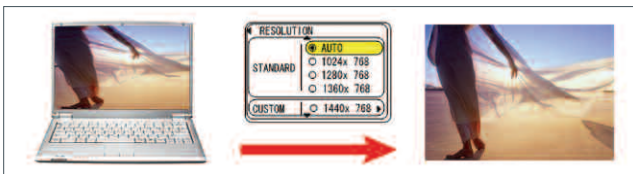

- **Whiteboard Mode and Blackboard Mode** - Images displayed on whiteboards may be too bright, whiteboard mode changes the gamma curve to reduce the peak white brightness allowing users to enjoy the benefits of a bright projector but reducing potential health and safety risks of looking directly into one. Blackboard mode provides better colour balance when projecting onto a coloured background.

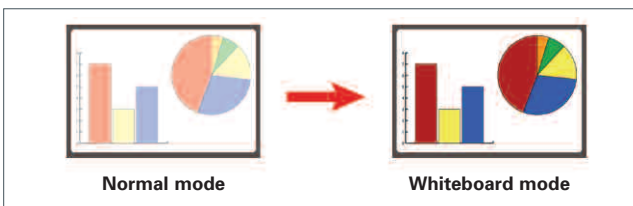

- **Anti Theft Features** - CP-X265 has an impressive suite of anti-theft measures - security bar is a steel bar embedded in the chassis which provides a strong anchor point for a chain. It is also a visible security feature to prevent casual removal:



- Pin-Lock is a means of in-activating the projector until a user preset key sequence is input.
- 'My Screen Lock' allows users to personalise the start up screen with a warning or ownership message and lock this screen with a pin code number.
- Transition detector that operates whenever the projection angle or settings are changed from the installed position - this is locked by a numeric pin code.

CP-X265 SPECIFICATION

OPTICAL

LCD Panel	0.63" P-Si TFT x3 with MLA
Resolution	1024 dots x 768 lines
Brightness	(Normal) 2500 ANSI Lumens (Whisper) 2000 ANSI Lumens
Contrast Ratio	500:1 (typ)
Lens	F1.7 -1.9, f=18.9 - 22.6mm, Manual Zoom x 1.2
Lamp	200W UHB
Focus Distance	0.9-9.3m (Wide), 1.1m-11.2m (Tele)
Distance to Width Ratio (:1)	1.52 (Wide), 1.86 (Tele)
Diagonal Display Size	30-300" (60"@1.8m, Wide)

COMPATIBILITY

Computer Compatibility	IBM Compatible VGA, SVGA, XGA, SXGA/SXGA+, UXGA Capability, MAC 13", MAC 16" (Pixelworks chip)
Video Compatibility	NTSC/PAL/SECAM/PAL-M,N/NTSC4.43 SDTV: 525i(480i), 525p(480p), 625i(576i) HDTV: 750p (720p@50/60Hz), 1125i(1080i@50/60Hz)
Plug & Play	DCC2B
Frequency Range	FV 56-120Hz, FH 31.5-106kHz

FEATURES

Speakers	1 x 1W
Other	Freeze, Magnifying, Blank, Auto adjustment, Search, Page Up & Down (for USB mouse function), Equalizing Gamma Correction, 2-3 pull down, Progressive Scan, Noise Reduction, Auto V keystone +/- 30°, My Screen, My Memory, My Button, Blackboard/Whiteboard Mode, Input Source Naming (English), Easy Lamp replace from Top, Easy Filter Change with sliding system, Serial Number label on side, Quick On (3 sec target), Direct On, Direct Off
Network	Controlling & Monitoring, WEB control, e-shot, Scheduling function

CONNECTORS

Computer Input	2 x 15-pin Mini D-sub
Computer Output	1 x 15-pin Mini D-sub
Video Input	1 x RCA Jack (for composite) 1 x S-Video Jack Mini-DIN 4-pin
Audio Input	3 x RCA Jack (for component) 2 x Stereo Mini Jack 1 x RCA Jack
Audio Output	1 x Stereo Mini Jack
Control	1 x 9-pin D-sub for RS232C Control
Mouse	1 x USB
Network Interface	1 x RJ-45

POWER

Power Supply	100-120/220-240V, 50/60Hz, 3.3A/1.4A
Power Consumption	310W

PHYSICAL

Dimensions (W x H x D)	306 x 106 x 249mm (excluding feet and extrusions)
Weight	3.3Kg
Noise Level	39dB/33dB

CERTIFICATION

UL60950/C-UL, FCC Part 15, Class B, CE, EN60950, WEE

OPTIONAL ACCESSORIES

Replacement Lamp DT00751

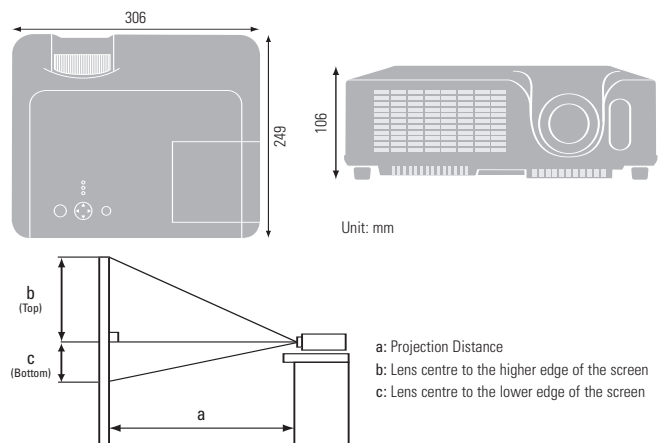

Image Size 16:9

Screen Size (Diagonal)	Projection Distance (a)		Screen Height (cm)	
	min. (m)	max. (m)	b (top)	c (bottom)
40" (1.0)	1.2	1.4	55	6
60" (1.5)	1.8	2.1	82	9
100" (2.5)	3.0	3.6	137	15
150" (3.8)	4.5	5.4	206	23
200" (5.1)	6.0	7.2	274	30
300" (7.6)	9.0	10.8	411	46

Image Size 16:9

Screen Size (Diagonal)	Projection Distance (a)		Screen Height (cm)	
	min. (m)	max. (m)	b (top)	c (bottom)
40" (1.0)	1.3	1.5	51	-2
60" (1.5)	1.9	2.3	77	-2
100" (2.5)	3.2	3.9	129	-4
150" (3.8)	4.9	5.8	193	-6
200" (5.1)	6.5	7.8	257	-8
300" (7.6)	9.8	11.7	386	-12